

DONALD R. BOYD
MSGT, USAF

INTEGRATED STEREO AMPLIFIER

SA-9100

OPERATING INSTRUCTIONS

KCW
FVW

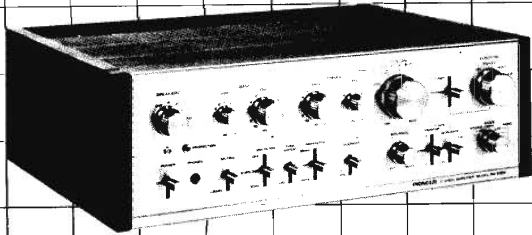

 PIONEER

FEATURES

The Preamplifier Section Phono Equalizer With Differential Amplification Circuit

No cost or effort has been spared to provide the most exact and stable phono equalization of any stereo amplifier we know. The equalizer unit, sealed in a special case to shield it from leakage and hum, uses a total of 10 transistors. Its front end is a differential amplifier circuit providing stable operation bias and unvarying performance after long-term use. The equalizer output is a single ended push-pull (SEPP) design. Although the phono inputs are very sensitive, they can, on the other hand, handle input signals up to 250mV without causing overload, so that practically any dynamic phono cartridge can be accommodated. Specially selected — and quite expensive — parts are employed throughout: low-noise nichrome processed metal-film resistors (sputtering process) with a tolerance of $\pm 1\%$, styrol capacitors of $\pm 2\%$ tolerance as found in laboratory gear. Balanced (+) and (–) power is supplied to the equalizer, resulting in superior dynamic range and stability, and special steps have been taken to prevent click noises. With these features, the equalizer stays within $\pm 0.2\text{dB}$ of the RIAA phono equalization curve.

Accurate, Versatile Twin Tone Controls With Four Working Frequencies

The tone control circuits are active NFB types sealed in a special case. Two bass controls (working points at 50 and 100Hz) and two treble controls (10kHz and 20kHz) are provided, permitting practically any desired frequency contour to be obtained. The control knobs have click-stops, each increment representing 2dB change. A tone control defeat switch lets the signal bypass the tone controls, giving absolutely flat response as required for measurements etc. Parts used in the tone control circuits are of the same narrow tolerances as in the equalizer.

Additional Electronic Protection Circuit

Speakers and output transistors are further protected by an electronic circuit that shuts off the power at the first sign of trouble such as a short-circuit in the speaker leads. A pilot lamp on the front panel lights when this protection circuit has been activated.

Generous Power Supply Unit, Wide Power Bandwidth

The ripple filters in the power supply units have a large capacitance of 15,000 μF in each of (+) and (–) sides. Power bandwidth ranges from 20 to 20,000Hz, meaning that full power is available at any point of the audible frequency spectrum.

Preset Level Controls For Phono 2, Aux 2, Speakers B

For comparative listening tests, and for balancing the volume levels of different program sources, three preset level controls are provided on the rear panel.

Constant-Current Circuits Solve Vital Problem Of All Transistor Amplifiers

In the past, all transistor amplifiers were afflicted by shifting of transistor working points in accordance with changing input signal levels. This could lead to instabilities and crossover distortions when the signal level moved out of the transistors' range of linearity. In a radical breakthrough, Pioneer has solved this problem, employing constant-current circuits at two stages to keep transistor operation stable regardless of signal level.

Presetting Of Volume Range

Where the full maximum volume is never needed — with speakers of insufficient power handling ability, for example — the maximum volume level can be pre-set at -15dB or -30dB . The volume control knob then covers the reduced range, permitting finer adjustments.

Active High And Low Filters With Selectable Cut- Off Frequencies

Active circuits with a cut-off steepness of 12dB/octave have been provided as high and low filters. Their cut-off frequencies can be selected to permit noise reduction only in the desired range: below 8Hz (subsonic) or 30Hz for the low filter, above 8kHz or 12kHz for the high filter.

Provisions For Two Tape Decks, Tape Duplicating, Three Pairs Of Speakers

Two tape decks can be connected for recording, playback, and tape-to-tape duplicating in either direction. Up to three pairs of speakers can be driven individually or A+B, A+C.

Elegant Styling Matches Technical Excellence

The functional layout of the control panel is as practical as it is beautiful. The natural walnut cabinet provides protection and adds decorator looks. Combination with other Pioneer hi-fi components will result in a music system of well-matched beauty in sound and appearance.

HOW TO ASSEMBLE A COMPONENT STEREO SYSTEM

The SA-9100 is an integrated stereo amplifier, meaning that it combines a preamplifier and power amplifier in one unit. For a stereo system, you will need at least one pair of speaker systems and one program source such as a turntable, a stereo tuner, or a tape deck. These should be of very high quality comparable to the SA-9100.

Fig. 1 shows a stereo system with all components that can be connected to the SA-9100.

The SA-9100 can also serve as the heart of a multi-amplifier system of the highest caliber, or of a 4-channel system as described on page 15.

HOW TO CHOOSE OTHER COMPONENTS

Pioneer manufactures a wide variety of all types of hi-fi components. These match your SA-9100 perfectly, in their technical aspects as well as in styling. In any event, observe the following hints when selecting other units for your stereo system.

Tape deck (reel-to-reel or cassette)

Pay attention to wow & flutter, signal-to-noise ratio, frequency response. Among reel-to-reel decks, three-head models are preferable because of better recording control.

Turntable

Shop for low wow & flutter rating, high signal-to-noise ratio, and wide frequency response of pick-up cartridge.

Tuner

Among tuner specifications, pay special attention to selectivity, signal-to-noise ratio, stereo channel separation, image rejection, AM suppression.

Speaker systems

Speaker systems should have an impedance of 4 to 16 ohms, and frequency response curves without conspicuous dips and peaks. If at all possible, use identical speakers for the left and right channels.

According to their enclosures, speaker systems can be classified as "closed box" and "bass reflex" types. By the number of speaker units, they are grouped into "full range," "2-way," "3-way," etc. systems. There are floor-standing and bookshelf types, plus omnidirectional systems that can be placed anywhere. Maximum input power is also important, because the SA-9100 is a very powerful amplifier.

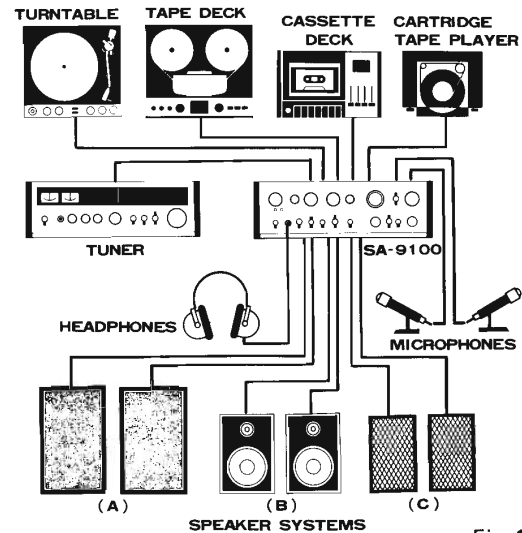

Fig. 1

PLACEMENT AND CONNECTIONS

WHERE TO PLACE THE SA-9100

When selecting a place for your SA-9100, avoid locations that are,

- near stoves or other heat sources,
- in direct sunlight,
- poorly ventilated, very moist or dusty,
- wobbly or slanted,
- near a storage place of alcohol or other easily inflammable chemicals.

CONNECTION OF SPEAKER SYSTEMS

The SA-9100 has three sets of speaker output terminals (A, B and C) and can accept two pairs of speaker systems. When using only one pair of speakers, connect them to the A terminals as follows.

Use common two-pole lead wire, preferably with different colors for the two leads. Speaker wire is often supplied with the speakers.

Connect the speaker for the right channel (marked "R" in Fig. 2) to the speaker terminals marked "R" on the SA-9100.

Connect the left channel speaker ("L" in Fig. 2) to the speaker terminals marked "L" on the SA-9100.

Be sure to connect the plus (+) terminal on the SA-9100 (the upper terminal) to the (+) terminal on the speaker, and the minus (-) terminal (lower terminal) on the SA-9100 to the (-) terminal on the speaker.

A second (third) pair of speakers can be connected to the B (C) terminals the same way.

For connection, remove about 10mm (1/3 inch) of insulation from the lead wires. If the wire core is stranded, twist it to prevent hair wires from sticking out. On the (+) side, push the red clamp-lever on the terminal up and insert the wire end into the hole, then release the lever — the wire will be clamped securely in the terminal. On the (-) side, push the black clamp-lever on the terminal down, insert the wire and release the lever. Refer to Fig. 3.

Placement of speaker systems

The listening room — its size, shape, materials of walls, floor and ceiling, draperies, furniture, etc. — have considerable influence upon the sound. Generally, placing the speakers in corners or with their backs against the wall will improve bass response. If the room sounds too "live," i.e. with strong reverberations of high-range sound, it can be improved by heavy curtains and draperies, upholstered furniture and other sound-absorbing material. To obtain clear stereo channel separation, place the speakers sufficiently far apart. Your listening position and the two speakers should form an equal-sided triangle.

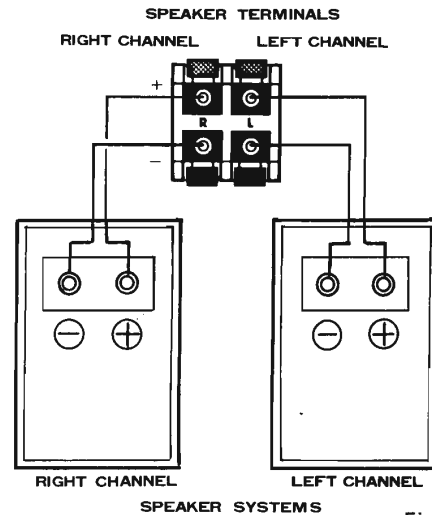

Fig. 2

NOTES:

1. The sound volume of the B speakers is adjustable with the B SPEAKER LEVEL control from 0 (meaning full volume) to -14dB. This is practical for conducting comparative listening tests with speakers of different efficiency. Connect the loudest speakers (those with the highest sound pressure level) to the B speaker outputs, and the speakers of lower efficiency to the A or C outputs. While switching back and forth, adjust the B level control so that both pairs produce the same sensation of loudness. Note that the level control has no effect when the speaker selector is set at A+B.
2. If two pairs of speakers are to be used at the same time (A+B, or A+C), each speaker must have an impedance of 8 ohms or more.

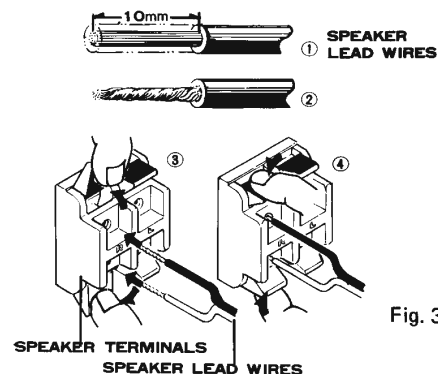

Fig. 3

CONNECTION OF TURNTABLE

Two stereo turntables with magnetic phono cartridges can be connected to the PHONO 1 and PHONO 2 inputs. With both phono inputs, the upper terminal is for the left channel output cable from the turntable, the lower terminal for the right channel output cable. The ground wire from the turntable should be connected to the GND terminal on the SA-9100.

Outputs from a second turntable — or a second tonearm on the same turntable — can be connected to the PHONO 2 inputs in the same manner. The input sensitivity of the PHONO 2 inputs can be adjusted within a range of 2.5mV ~10mV by turning the level control on the rear panel. Thus, different phono cartridges can be accommodated. Connect the “louder” of two phono cartridges to the PHONO 2 inputs, the one producing lower signal output to the PHONO 1 inputs. Then, by turning the level control, the volume levels can be balanced.

CONNECTION OF TUNER

The outputs of an AM/FM stereo tuner can be connected to the TUNER inputs with a separately available cable. Again, the upper terminal is for the left channel, the lower for the right channel.

A second tuner can be connected to the AUX 1 or AUX 2 inputs.

CONNECTION OF TAPE DECKS

Two tape decks can be connected to the SA-9100 for recording, playback, and tape-to-tape duplicating. The necessary connection cords are usually supplied with the tape deck.

Connections for recording

Connect the tape deck's LINE (or AUX or RADIO) inputs with the TAPE 1 REC outputs of the SA-9100. Upper terminal: left channel.

In the same way, a second tape deck can be connected to the TAPE 2 REC outputs.

Connections for playback and monitoring

Connect the tape deck's LINE (or MONITOR) outputs with the TAPE 1 MON inputs of the SA-9100. Upper terminals: left channel.

In the same way, a second tape deck can be connected to the TAPE 2 MON inputs.

Connection via REC/PB connector

Please note that the REC/PB connector corresponds to the TAPE 2 REC and TAPE 2 MON terminals — the signal must be controlled with the TAPE MONITOR switch on the front panel.

Also, in the case of a three-head tape deck, connection via a DIN-cable may sometimes cause crosstalk. With three-head tape decks, connection to the REC outputs and MON inputs via regular phono cables is preferable.

NOTES:

1. A moving coil (MC) cartridge of low output voltage can be used only in combination with a separate booster transformer or head amplifier.
2. The input impedance of the INPUT PHONO 1 on the rear panel is 50k Ω /1kHz. The input impedance of the INPUT PHONO 2 can be switched to each of three positions: 25k Ω , 50k Ω , 100k Ω . If, for example, a stereo phono cartridge has rated load resistance of 100k Ω , set the PHONO 2 IMPEDANCE switch to position 100k Ω .

NOTE:

Instead of the just described recording and playback connections, the tape deck can be connected to the REC/PB connector of the SA-9100 if an identical connector is provided on the tape deck, too. The required DIN-cable is available at all hi-fi and radio stores. This single cable completes all playback and recording connections. Be sure, the DIN-cable is for between tape deck to amplifier.

WHAT ARE THE AUX 1 AND AUX 2 INPUTS FOR?

These two pairs of inputs are provided to accommodate additional program sources such as an 8-track cartridge tape player, the sound track from a TV set, or a second tuner.

Input sensitivity of the AUX 2 inputs can be adjusted with the level control on the rear panel. Counterclockwise rotation of the level control reduces sensitivity, so that program sources with relatively high output voltage can be accommodated.

PURPOSE OF THE PRE OUT AND POWER IN JACKS

PREAMPLIFIER AND POWER AMPLIFIER CAN FUNCTION SEPARATELY

The preamplifier section of the SA-9100 can be used alone, and its output signal supplied to a separate high-powered amplifier to service large halls, theaters, etc. Or, another power amplifier can be compared with that of the SA-9100 by switching back and forth. Also, the signal from the PRE OUT outputs — which has passed through the tone controls, filters, etc. — can be recorded on tape.

For such applications, the SEPARATION switch on the rear panel must be moved to either of its lower two (SEPARATED) positions. These two positions are for turning the SUBSONIC filter in the power amplifier ON and OFF. For an explanation of the subsonic filter, see page 9, item LOW FILTER.

A MULTI-AMPLIFIER SYSTEM CAN BE ASSEMBLED

By adding an electronic crossover network and one or two additional power amplifiers, a high-grade multi-amplifier system can be built.

The electronic crossover network divides the audible frequency spectrum into two (low, mid-high) or three (low, medium, high) ranges, and each is then augmented in a separate power amplifier and reproduced via special loudspeakers. Fig. 4 shows such a two-way multi-amplifier installation. Compared with conventional full-range amplification, it offers numerous advantages: Less or no intermodulation distortion in speakers and amplifiers; precise matching of crossover frequencies to speaker characteristics; individual level control of each band in each channel; greater overall power; elimination of conventional, passive crossover networks in the speaker systems, with their inherent problems.

In a two-way multi-amplifier system, connections are made as described at the right.

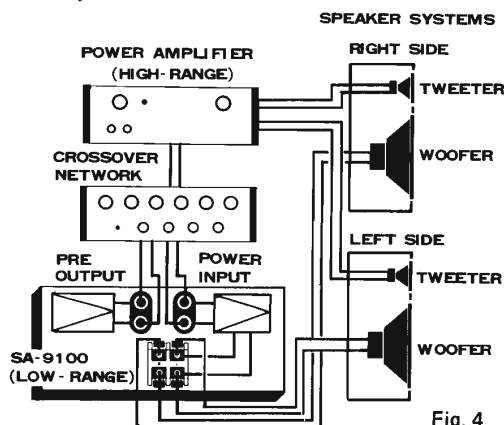
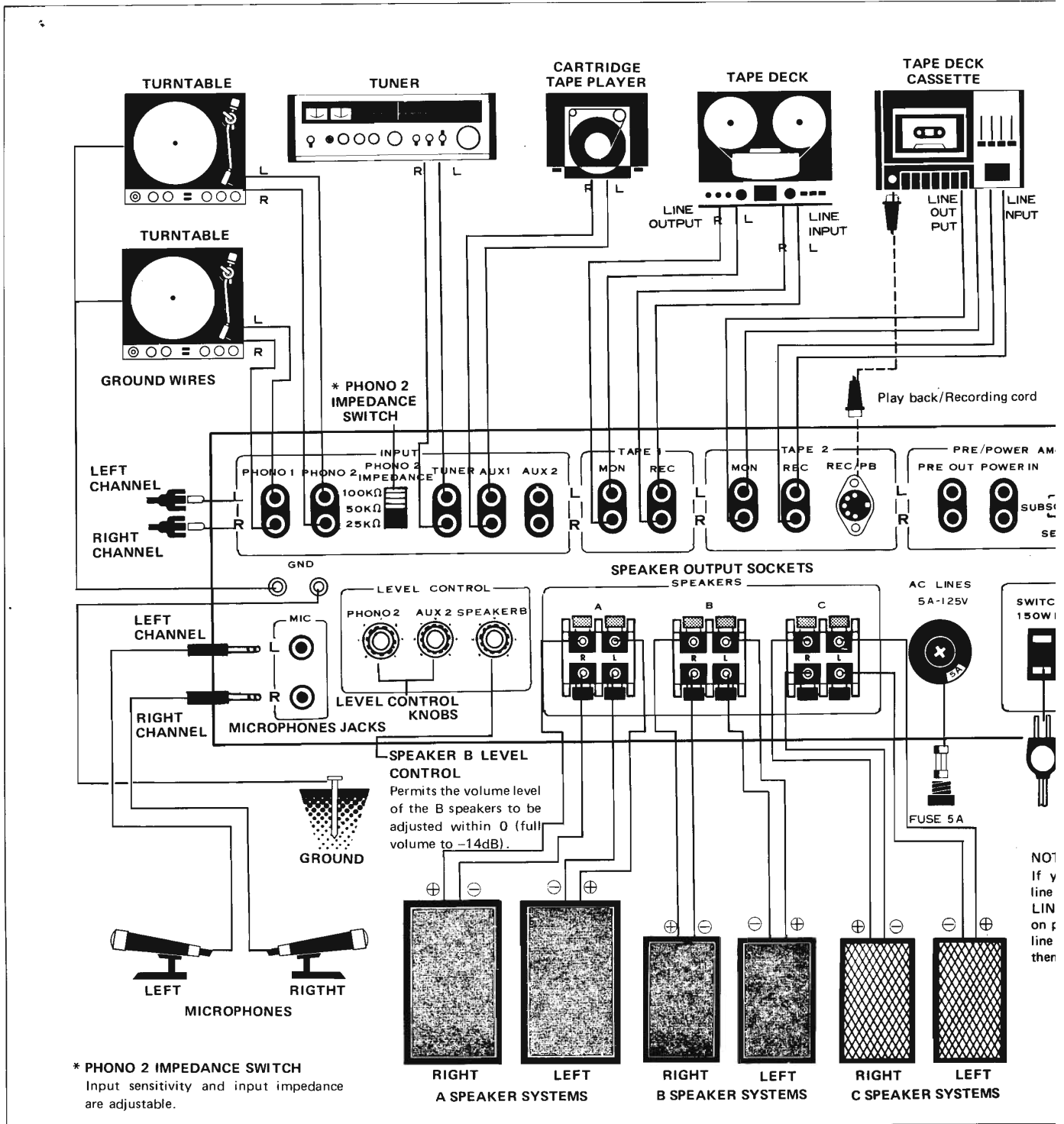

Fig. 4

Connection

1. Connect PRE OUT jacks of SA-9100 to inputs of electronic crossover network.
2. Connect LOW range outputs of electronic crossover network to POWER IN jacks of SA-9100.
3. Connect MID-HIGH outputs of electronic crossover network to inputs of second power amplifier.
4. Connect woofers to speaker outputs of the SA-9100. Connect mid-high-range speakers to speaker outputs of second power amplifier.
5. Set separation switch on the SA-9100 to SEPARATED position.

CONNECTION DIAGRAM



LINE VOLTAGE AND FUSE

The SA-9100 is available in two models: one model operates only on 120V, and the other operates on one of the five line voltages; 110V, 120V, 130V, 220V and 240V. If your SA-9100 is the latter model, set the unit to the proper line voltage by following the procedure described below.

CHANGING LINE VOLTAGE SETTING AND FUSE

To remove the fuse, turn the fuse cap located on the line voltage selector in the direction of the arrow.

Then remove the fuse plug from the unit. Put the fuse plug back so that the proper line voltage marking can be seen through the cut in the edge of the plug. Whenever the position of the selector is changed, check the rating of the fuse. A 2.5A fuse is to be used for either 220V or 240V operation and a 5A fuse for 110V, 120V or 130V operation. If the rating of the fuse is correct, replace cap.

FUSE REPLACEMENT

When the fuse blows, remove the fuse cap and replace the fuse with a new one. See Fig. 5.

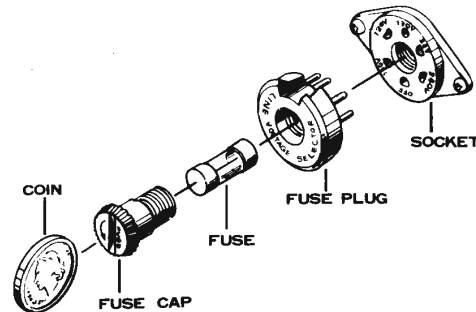
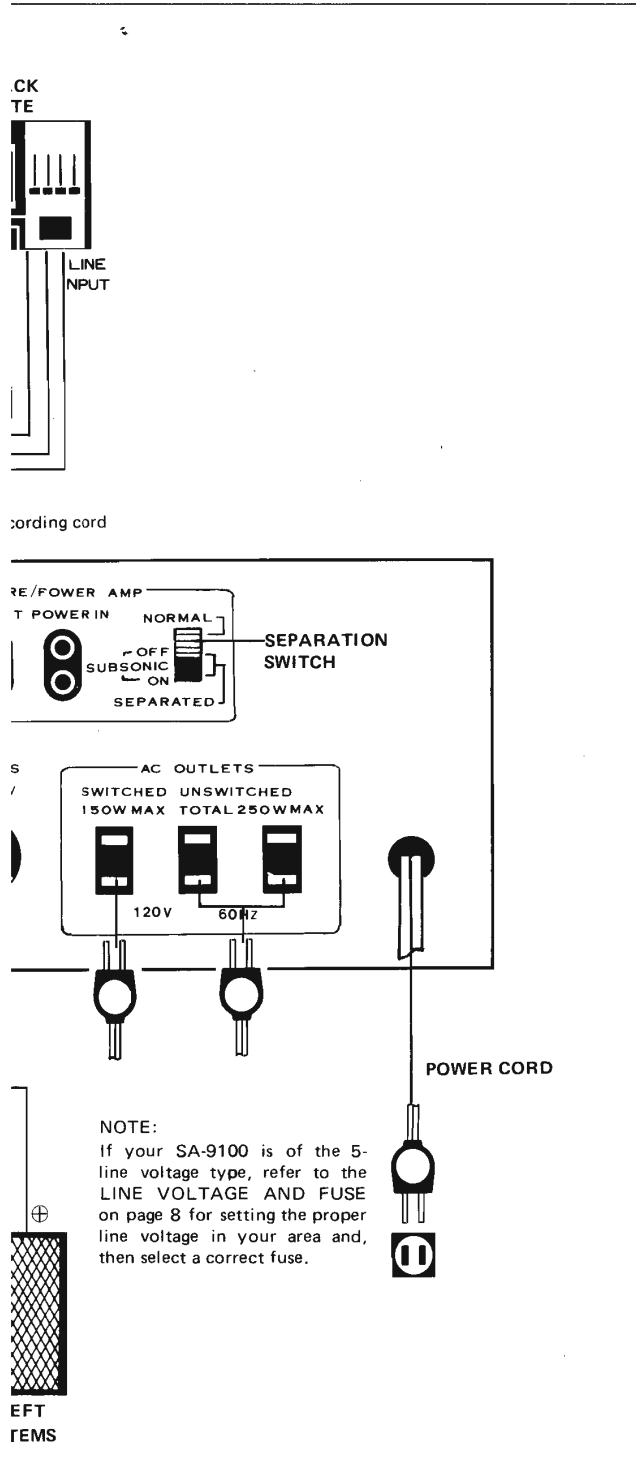

Fig. 5

FRONT PANEL FACILITIES

POWER SWITCH, PILOT LAMP

Turns the power to the unit ON and OFF. Also controls the AC outlet marked SWITCHED on the rear panel. The pilot lamp lights when the power is on.

SPEAKERS SWITCH

Selects the speaker system(s) to be driven.

- A Speaker systems connected to speaker outputs A operate.
- B Speaker systems connected to speaker outputs B operate.
- C Speaker systems connected to speaker outputs C operate.
- A+B . . . Both speaker systems A and B operate.
- A+C . . . Both speaker systems A and C operate.
- OFF . . . All speakers off. Use this position when listening through headphones.

PROTECTION PILOT LAMP

When the built-in protector circuit operates to shut off the power to the speakers, this lamp will light. This happens when there's a short-circuit in the speaker leads, or when combined speaker impedance is below 2-ohm, causing overload.

NOTE:

The lamp will also light for 3 to 6 seconds after you turn on the power, and the speakers will remain silent. This is no indication of trouble. The protector circuit is so designed that it will keep the speakers muted for the first few seconds, because they might produce unpleasant noise while the amplifier is still warming up. Also refer to page 13, item "THE PROTECTOR CIRCUIT."

HEADPHONE JACK

Stereo headphones can be plugged into this jack. A wide variety of quality headphones is available from Pioneer.

LOW FILTER SWITCH

The low filter is used to eliminate low-frequency noise such as turntable rumble, etc.

- SUBSONIC . . . Frequencies below 8Hz are attenuated by 12dB/octave. Although such subsonic frequencies are inaudible to the human ear, they can cause intermodulation distortions and even damage to the loudspeakers. It is advisable to leave the switch in this position at all times, even if no record rumble etc. is heard.
- 30Hz Frequencies below 30Hz are attenuated by 12dB/octave. Use this position to eliminate record rumble and other low-frequency noise.
- OFF No attenuation of low and subsonic frequencies. Use this position for measurements, when the widest possible bass response is required.

BASS CONTROL

This pair of twin controls are for tone adjustments in the bass range.

- 100Hz knob . . . Controls bass frequencies at and below 400Hz and also at 100Hz by up to $\pm 10\text{dB}$, in click-stops of 2dB.
- 50Hz knob . . . Re-controls frequency range below 100Hz of tone quality being controlled by the 100Hz knob and also by up to $\pm 6\text{dB}$, in click-stops of 2dB.

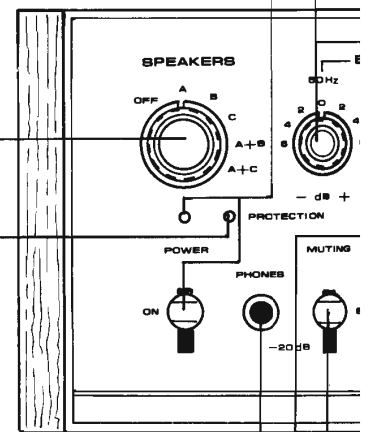

MUTING SWITCH

In position -20dB, the listening volume is instantly reduced by 20dB. Without having to turn the volume control, you can reduce the sound level.

TONE DEFEAT SWITCH

In position On, the four bass and treble controls do not function — the amplifier produces flat frequency response. This is useful for frequency response measurements of phono cartridges, loudspeakers and the acoustic characteristics of the room.

TREBLE CONTROL

These twin controls are for tone adjustments in the high sound range.

10kHz knob . . . Controls high-frequencies at and above 2.5kHz and also at 10kHz by up to ± 10 dB in click-stops of 2dB.

20kHz knob . . . Re-controls frequency range above 10 kHz of tone quality being controlled by the 10kHz knob and also by up to ± 6 dB in click-stops of 2dB.

NOTE:

For a detailed description of the twin tone controls and how to use them, see item "THE TWIN TONE CONTROLS" on page 11. Flat frequency response can be obtained in either of two ways: by setting all four knobs at center position "0," or by setting the TONE DEFEAT switch to ON.

LEVEL SET CONTROL

The outer ring of the volume control serves to limit the output level of the SA-9100. This helps to protect speakers of small power handling ability, but also permits finer volume adjustments at low-to-medium listening levels.

-30dB . . . Output level reduced by 30dB.

-15dB . . . Output level reduced by 15dB.

0 No reduction. Full output level available.

A detailed description of level presetting is given in item "THE LEVEL SET CONTROL" on page 11.

VOLUME CONTROL

Controls the listening volume. Clockwise rotation increases the volume.

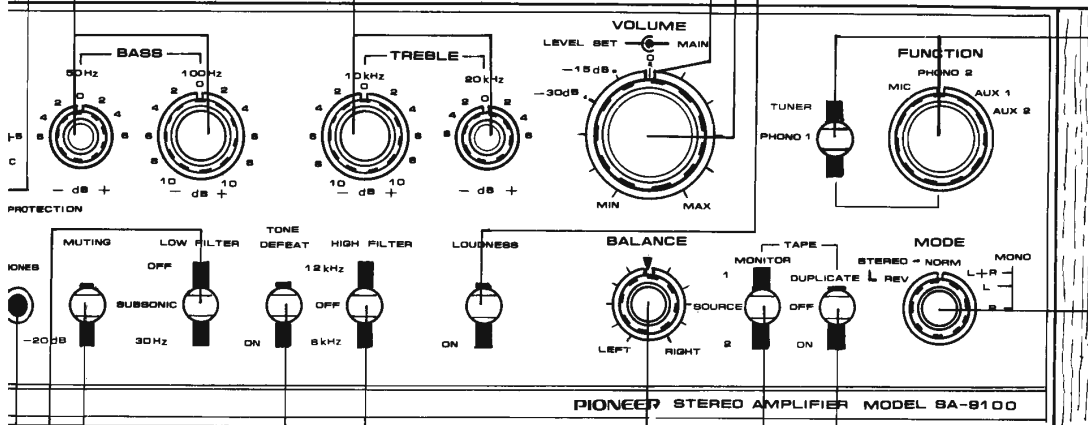

BALANCE CONTROL

For balancing the relative sound volume of the left and right channel speakers. Clockwise rotation reduces the volume from the left speaker, counterclockwise rotation decreases the volume from the right speaker.

HIGH FILTER SWITCH

In position 8kHz (or 12kHz), frequencies above 8kHz (or 12kHz) are attenuated by 12dB/oct. This helps eliminate noise from scratchy records, tape and FM hiss, etc.

TAPE DUPLICATE SWITCH

Position ON is used for duplicating a tape with the help of two tape decks. For all other modes of operation, this switch must be left at OFF.

TAPE MONITOR SWITCH

Positions 1 or 2 of this switch are used only for tape playback and for monitoring a tape recording in progress. In all other cases, leave this switch in position SOURCE.

1 Tape playback or monitoring with tape deck connected to TAPE 1 REC outputs and TAPE 1 MON inputs.

SOURCE . . . For all other modes of operation such as record playing, radio reception, etc.

2 Tape playback or monitoring with tape deck connected to TAPE 2 REC outputs and TAPE 2 MON inputs, or to DIN-type REC/PB connector.

LOUDNESS SWITCH

Push this switch to obtain a more natural frequency contour at quiet listening levels. The human ear has different frequency response characteristics at high and low volume levels, and the loudness circuit automatically compensates for this deficiency by boosting the bass range when the volume is low.

The loudness circuit operates when the switch is pushed in. Function of the loudness circuit is linked to the VOLUME and LEVEL SET controls.

- LEVEL SET at 0 Loudness circuit functions at volume settings from MIN to about "11 o'clock."
- LEVEL SET at -15dB . . . Loudness circuit functions at volume settings from MIN to about "1 o'clock."
- LEVEL SET at -30dB . . . Loudness circuit functions at any position of the volume control.

FUNCTION SELECTORS

This combination of a lever switch and a rotary switch selects the program sources to be played.

LEVER SWITCH

TUNER Radio reception with tuner connected to TUNER inputs.

PHONO 1 Operation of turntable connected to PHONO 1 inputs.

When this switch is in bottom position, programs are selected by the rotary switch.

ROTARY SWITCH

MIC Use of microphones plugged into MIC inputs.

PHONO 2 Operation of turntable connected to PHONO 2 inputs.

AUX 1 Program source (cartridge tape player etc.) connected to AUX 1 inputs.

AUX 2 Program source (TV sound track etc.) connected to AUX 2 inputs.

MODE SWITCH

Selects stereophonic and monophonic listening modes.

STEREO NORM Normal stereophonic reproduction.

STEREO REV Stereophonic reproduction with reversed channels: left input signal to right speaker, right input signal to left speaker.

MONO L+R Monophonic reproduction. Mixed left-plus-right signal to both speakers.

MONO L Left input signal to both speakers.

MONO R Right input signal to both speakers.

THE TWIN TONE CONTROLS

Model SA-9100 has one pair of tone control knobs for the bass range, another pair for the treble range.

The larger BASS control knob permits bass response to be adjusted by $\pm 10\text{dB}$ at 100Hz . After passing through this control circuit, the signal can be adjusted again at 50Hz , by $\pm 6\text{dB}$, with the smaller control knob.

Similarly, the larger TREBLE control knob adjusts treble response at 10kHz by $\pm 10\text{dB}$. The signal can be further adjusted at 20kHz by $\pm 6\text{dB}$. Fig. 6(A) shows the obtainable frequency response curves when both controls are used together. If the larger knobs are left at "0" and only the smaller knobs used, these function as tone controls with turnover frequencies at 100Hz and 10kHz , respectively. Conversely, if both small controls are left an "0" and only the large knobs used, these act as tone controls with turnover frequencies at 400Hz and 2.5kHz . Fig. 6(B) illustrates these uses.

NOTE:

The numbers on the panel (50Hz , 100Hz , 10kHz and 20kHz denote the frequencies at which the tone controls will show maximum effectiveness, i.e. maximum boost or attenuation.

"Turnover frequency," on the other hand, denotes the frequency at which the control will produce a boost or attenuation of 3dB .

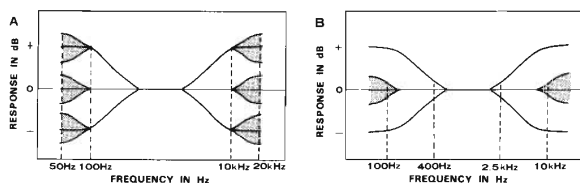

Fig. 6

THE LEVEL SET CONTROL

On model SA-9100, there is an outer ring around the volume control knob. With this LEVEL SET control, amplifier output can be reduced by 30dB or 15dB . This gives several advantages and new possibilities:

- When an amplifier as powerful as the SA-9100 is used for listening at quiet sound levels, the volume control has to be turned down almost to MIN, and fine adjustments within the soft range are difficult. If you reduce total amp power by 15 or 30dB with the level set control, the volume control will permit easier and finer adjustments in the remaining power range.
- Limiting of the power output also protects speakers, especially those of small input handling ability, from accidental damage that might occur when you turn up the volume to maximum by mistake. With small speakers, it is advisable to leave the LEVEL SET control at -15dB or -30dB at all times.

STEP-BY-STEP OPERATING INSTRUCTIONS

BEFORE OPERATION

. . . complete the following checks.

1. VOLUME control at MIN.
2. LEVEL SET control at 0.
3. MUTING switch at OFF (upper position).
4. TAPE MONITOR switch at SOURCE.
5. TAPE DUPLICATE switch at OFF.
6. SPEAKERS switch at correct position for speakers to be driven: A, B, C, A+B, or A+C.
7. MODE switch at STEREO NORM position.
8. BALANCE and all BASS and TREBLE controls at center position.
9. TONE DEFEAT switch at OFF (upper position).

RECORD PLAYING

1. If the turntable is connected to the PHONO 1 inputs, set the FUNCTION LEVER switch at PHONO 1. If the turntable is connected to the PHONO 2 inputs, first push the FUNCTION LEVER switch down, then set the FUNCTION ROTARY switch to position PHONO 2.
2. Set the turntable in operation.
3. Use the VOLUME, BASS, TREBLE, BALANCE, etc. controls to obtain the desired listening volume and tonal quality.

RADIO RECEPTION

1. Set the FUNCTION LEVER switch at position TUNER.
2. Operate the tuner as usual.
3. Use the VOLUME, BASS, TREBLE, BALANCE, etc. controls to obtain the desired volume and tonal quality.

USE OF MICROPHONES

1. Two microphones can be plugged into the MIC L and MIC R jacks on the rear panel for stereophonic operation. When using only one microphone, plug it into either MIC jack.
2. Push the FUNCTION LEVER switch down, then set FUNCTION ROTARY switch at MIC.
3. With two microphones, leave the MODE switch at position STEREO NORM. When using only one microphone, however, turn the MODE switch to position MONO L or MONO R, depending on which MIC input jack you're using.
4. Turn the VOLUME control back to MIN, then turn it up little by little. At high volume settings and if the microphones are close to the speakers, howling (acoustic feedback) may occur.

USE OF AUXILIARY PROGRAM SOURCES

Auxiliary program sources such as an 8-track cartridge tape player, sound track from a TV set, or a second radio tuner may be connected to the AUX 1 or AUX 2 inputs.

1. Push the FUNCTION LEVER switch down, then set

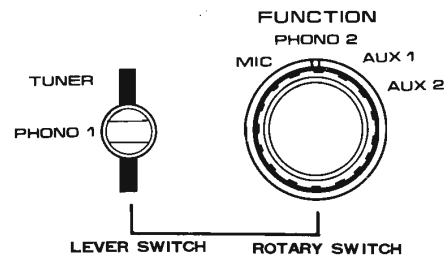

Fig. 7

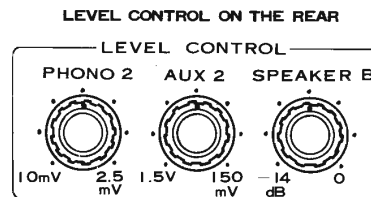

Fig. 8

FUNCTION ROTARY switch at position AUX 1 or AUX 2.

2. Operate the program source equipment as usual.
3. Use the VOLUME, BALANCE, BASS, TREBLE, etc. controls to obtain the desired volume level and tonal quality.

NOTE:

USEFUL HINTS FOR OPTIMUM OPERATION

1. *When two turntables (or two tonearms mounted on one turntable) are connected to the PHONO 1 and PHONO 2 inputs, one will probably sound a little louder than the other. This is due to different phono cartridge characteristics.
Connect the louder one to the PHONO 2 inputs, then turn down the PHONO 2 LEVEL control on the rear panel. Switching the FUNCTION selector alternately to PHONO 1 and PHONO 2, balance the turntable volume levels by adjusting the PHONO 2 LEVEL control. You can then conduct comparative listening tests with the two turntables without having to change the volume setting each time.*
2. *With the PHONO 2 IMPEDANCE switch on the rear panel, the impedance of the PHONO 2 inputs can be switched according to load resistance of the stereo phono cartridge you want to use. Try both 25k Ω and 100k Ω positions to listen to record music in your favorite taste, even though your phono cartridge is 50k Ω .*
3. *Microphones should be dynamic types of high impedance (approx. 50k Ω) and equipped with standard 6 ϕ plugs. A variety of high-grade microphones is available from Pioneer.*
4. *Be careful not to position the microphones close to the speakers and not to turn up the volume too high, as this may cause howling. It is also advisable to set the TONE DEFEAT switch at ON when using microphones.*
5. *If a program source is connected to the AUX 2 inputs, its sound volume can be balanced with that of other program sources (tuner, turntable) by adjusting the AUX 2 LEVEL control on the rear panel. Switch the FUNCTION selector alternately at AUX 2 and TUNER, for example, and adjust the AUX 2 LEVEL control until about the same volume is obtained from both sources.*

THE PROTECTION CIRCUIT

When you turn on the SA-9100, the protector pilot lamp will light and the speakers will remain silent for the first 3 to 6 seconds. This is caused by the protector circuit which keeps the output amplifier off until all components have attained a state of completely stable operation. Otherwise, unpleasant noise and, in extreme cases, damage to transistors and speakers might occur in the first few seconds.

If the protector pilot lamp remains lit and the speakers silent after 6 seconds, turn off the power and check the speaker connections and lead wires for a possible short-circuit. If the protector lamp lights during play and you hear a repeated clicking of the built-in relay, also turn off the power and check the speaker connections. The trouble may also be caused by very low speaker impedance — note that, when two pairs of speaker systems (A + B or A+C) are used, each system must have an impedance automatically, so after you have repaired the trouble, the amplifier will resume normal operation.

TAPE RECORDING, PLAYBACK AND DUPLICATING

TAPE RECORDING

The signal being played over the amplifier is always present at the TAPE 1 REC and TAPE 2 REC outputs for recording on tape. Select the program source with the FUNCTION selector as usual.

Please note that the VOLUME, BASS, TREBLE, BALANCE controls and filters have no effect upon the signal at the TAPE REC outputs. The signal is recorded as it comes from the program source. Recording levels must be adjusted with the controls on the tape deck.

Monitoring of a recording in progress

If the tape deck is a three-head type or equipped with monitor circuits, a recording in progress can be monitored by setting the TAPE MONITOR switch on the SA-9100 at position 1 or 2.

TAPE PLAYBACK

Playback on a tape deck connected to the TAPE 1 MON inputs: Set TAPE MONITOR switch to 1 (upper position).
 Playback on a tape deck connected to the TAPE 2 MON inputs: Set TAPE MONITOR switch to 2 (lower position).
 During tape playback, VOLUME, BASS, TREBLE, BALANCE, etc. controls of the SA-9100 function as usual. The FUNCTION selector switch, however, is meaningless during tape playback.

TAPE DUPLICATING

With two tape decks, you can duplicate tape-to-tape, or edit recordings while re-recording. For example, you can first tape a complete FM stereo program, with announcements and commercials, and later re-record on another tape while cutting out unwanted portions. For duplicating, proceed as follows.

1. Connect two tape decks as shown in Fig. 11.
2. Set the TAPE DUPLICATE at ON (lower position).
3. Record on a tape brand-new with one tape deck while playing back recorded tape with another tape deck (1 or 2).
4. Recording condition can be monitored while recording with tape deck 1 with TAPE MONITOR switch set to 1; likewise, recording condition can be monitored while recording with tape deck 2 with the switch set to 2 (See Fig. 11).

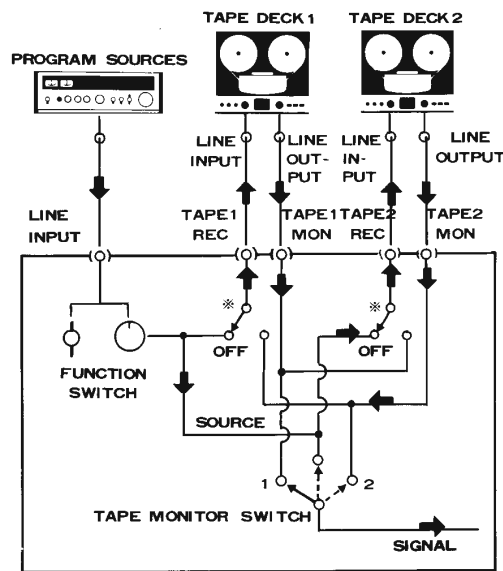

Fig. 9

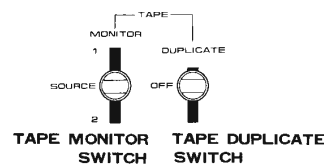

Fig. 10

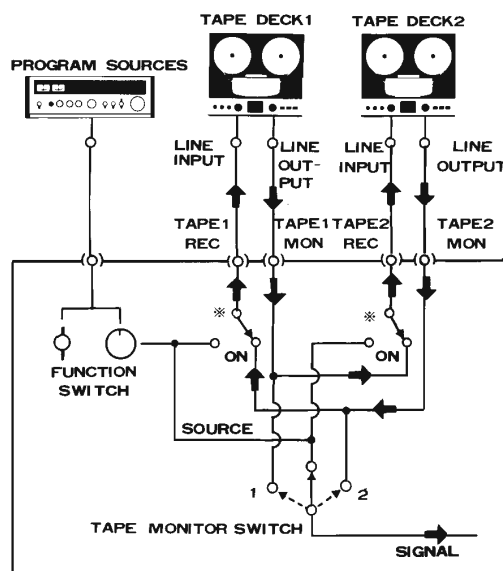

Fig. 11

HOW TO BUILD A 4-CHANNEL STEREO SYSTEM

Compared to 2-channel stereo reproduction, a 4-channel system offers numerous advantages. It can reproduce a life-like sound field including indirect and reverberated localization of sound sources at the front, sides and rear. It can create special effects such as "surround sound" and motion of sound sources in any desired direction. Where a 2-channel system will recreate only what takes place on the stage, a 4-channel system can re-build the total musical environment.

Such a 4-channel system can be built as shown in Fig. 12, by adding 4-channel decoder amplifier, and another pair of speakers for the rear channels.

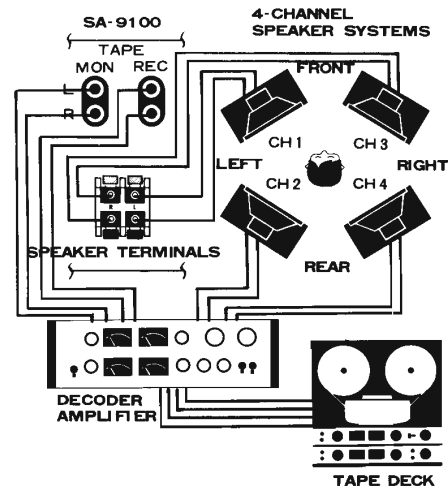

Fig. 12

CONDITIONS FREQUENTLY MISTAKEN FOR MALFUNCTION

In the case of a malfunction, please consult the following chart — the trouble is often caused by a mistake in operation. Also check the other components of your stereo system, because the malfunction may have occurred there.

	TROUBLE	PROBABLE CAUSE	REMEDY
RADIO RECEPTION	Intermittent high-pitched noise during FM reception.	Automobile ignition systems without noise suppression. High-frequency welding and plastic sealing equipment operating nearby.	Install high-gain special FM antenna. Direct antenna away from streets with heavy traffic. If noise persists, lodge complaint with radio communications authorities.
	More noise in FM stereo than in FM mono programs.	Reach of FM stereo broadcasts is only half that of mono broadcasts.	Install special FM antenna with high gain.
TURNTABLE OPERATION	Hum or buzzing noise present only when playing records.	a) Insufficient shielding of turntable output cables. b) System not grounded. c) TV transmitter nearby.	a) Replace turntable output cables with good, shielded cables. b) Check ground connections motor-to-amplifier, tonearm-to-amplifier, amplifier-to-ground. c) Consult Pioneer dealer or service station.
	Turntable picks up ham radio transmissions.	Ham radio transmitter operating nearby.	Consult Pioneer dealer or service station, discuss matter with ham radio operator.
	Noisy, unclear treble sound from records.	a) Worn pickup stylus. b) Worn record. c) Dust on pickup stylus. d) Faulty mounting or connection of pickup cartridge. e) Stylus tracking force too high or too low. f) TREBLE controls turned up too high.	Check points (a) thru (e). f) Turn down treble controls.
	Howling occurs when volume is turned up.	Turntable placed too close to speakers, or on unstable surface.	Remove turntable farther from speakers. Turn down BASS controls. Install shock-absorbing pads under turntable.

SPECIFICATIONS

Semiconductors

Transistors	63
Diodes	30

Power Amplifier Section

Circuitry	2-stage Differential Amplifier, Direct Coupled Pure Complementary OCL
-----------	---

Continuous Power Output

20Hz~20kHz	(Both channels driven) 60W+60W (8Ω), 75W+75W (4Ω)
1kHz (Both channels driven)	65W+65W (8Ω), 85W+85W (4Ω)
1kHz (Each channel driven)	75W/75W (8Ω), 100W/100W (4Ω)

Harmonic Distortion

(Continuous Power Output)	Less than 0.1%
(1W+1W Power Output)	Less than 0.04%

Intermodulation Distortion

(Continuous Power Output)	Less than 0.1%
(1W+1W Power Output)	Less than 0.04%

Power Bandwidth (IHF, Both channels driven)

	5Hz ~ 40kHz (H.D. 0.1%)
	7Hz ~ 80kHz ± 1 dB

Frequency Response

Input Sensitivity/Impedance

POWER AMP IN	500mV/50kΩ
Output, Speaker	A, B, C, A+B, A+C (4 ~ 16Ω)
Headphones	4 ~ 16Ω

Damping Factor (1kHz, 8Ω)

	More than 70
--	--------------

Hum & Noise (IHF, Short-circuited, A Network)

	More than 95dB
--	----------------

Residual Hum & Noise

(8Ω, Pre & Power-amplifier)	Less than 1mV (0.13μW)
-----------------------------	------------------------

Subsonic Filter

	8Hz (12dB/oct)
--	----------------

Preamplifier Section

Circuitry

Equalizer-amplifier	1st Stage Differential Amplifier, 3-stage Direct Coupled SEPP NFB type
Control-amplifier	1st Stage Differential Amplifier, 3-stage Direct Coupled NFB type

Input Sensitivity/Impedance

PHONO 1	2.5mV/50kΩ
PHONO 2	2.5mV ~ 10mV/25kΩ, 50kΩ, 100kΩ

PHONO Overload Level

(rms/p-p)	250mV/700mV
MIC	2.0mV/50kΩ
TUNER	150mV/100kΩ
AUX 1	150mV/100kΩ
AUX 2	150mV ~ 1.5V/50kΩ ~ 100kΩ
TAPE MONITOR 1, 2	150mV/100kΩ
TAPE MONITOR 2 (DIN connector)	150mV/100kΩ

Output Level/Impedance

TAPE REC 1, 2	150mV
TAPE REC 2 (DIN connector)	30mV/80kΩ
PRE AMP OUT	2V/8Ω

Harmonic Distortion

(20Hz ~ 20kHz)	Less than 0.03%
----------------	-----------------

Frequency Response

PHONO (RIAA equalization)	30Hz ~ 15kHz ± 0.2 dB
MIC	10Hz ~ 10kHz ± 1 dB
TUNER, AUX, TAPE MON	10Hz ~ 70kHz ± 1 dB

Tone Control

BASS	Main Control	± 10 dB(100Hz)
	Sub Control	± 6 dB(50Hz)
TREBLE	Main Control	± 10 dB(10kHz)
	Sub Control	± 6 dB(20kHz)

Filter

SUBSONIC	8Hz (12dB/oct)
LOW	30Hz (12dB/oct)
HIGH	8kHz, 12kHz (12dB/oct)

Loudness Contour (Volume

control set at -40dB position) +10dB (100Hz)

Hum & Noise (IHF, Short-circuited, A Network)

PHONO	More than 80dB
MIC	More than 70dB
TUNER, AUX, TAPE MON	More than 90dB

Muting

Level Set	0dB, -15dB, -30dB
-----------	-------------------

Miscellaneous

Power Requirements	AC 120V 60Hz or AC 110V, 120V, 130V, 220V and 240V 50/60Hz. (Switchable)
--------------------	--

Power Consumption (Max.)

	400W
--	------

AC Outlets

	Switched 1, Unswitched 2
--	--------------------------

Dimensions (overall)

	430(W) x 138(H) x 341(D)mm
	16-15/16(W) x 5-7/16(H) x 13-7/16(D)in.

Weight

Without Package	13.6 kg (29 lb 15oz)
With Package	15.6 kg (34 lb 5oz)

Furnished Parts

Hex. Wrench	1
Factory Tested Data	1
Operating Instructions	1
5-voltage Model; Fuse 2.5A	1
Fuses 5A	1

NOTE:

Specifications and the design subject to possible modification without notice due to improvements.

How to use Hex. Wrench

In case of slack of level set knob, tighten the 2 screws of Level set knob.

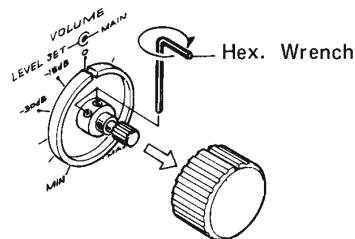

AMPLIFIER CHARACTERISTICS

POWER BANDWIDTH

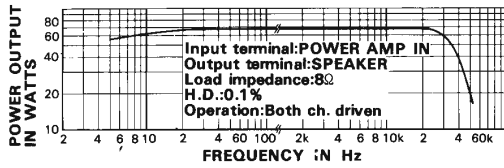

DAMPING FACTOR

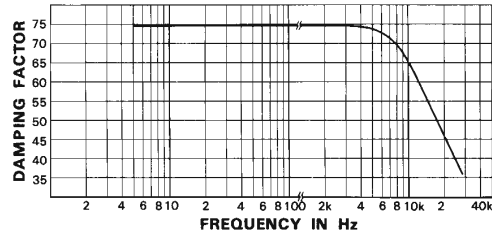

PHONO EQUALIZATION ACCURACY

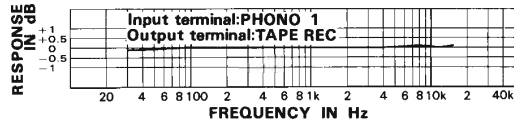

LOW AND HIGH FILTERS

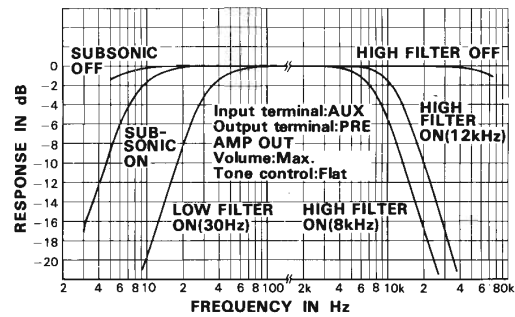

MAX. PHONO INPUT LEVEL

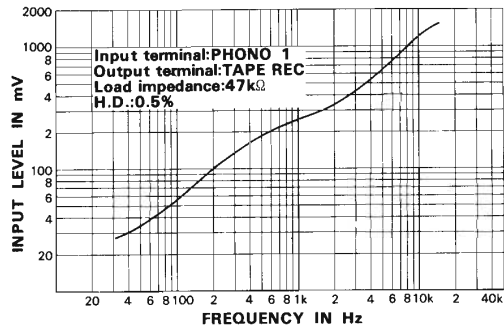

TWIN TONE CONTROLS (MAIN)

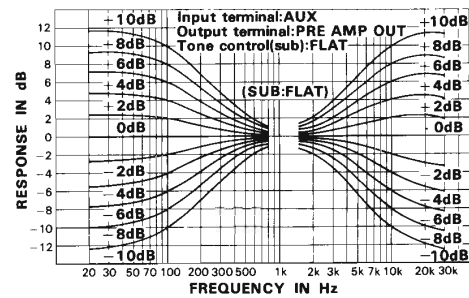

OUTPUT POWER VS. HARMONIC DISTORTION

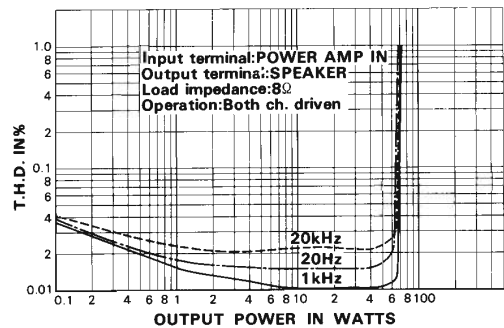

TWIN TONE CONTROLS (SUB)

